

Equipment identification: _____

Date : _____

Standard Milling Machine

Standard Milling Machine

Standard Milling Machine Parts

1. Spindle shaft
2. Command console
3. Spindle
4. Taper
5. Cutter
6. Table

Safety Devices

- A Emergency Stop Button
- B Solid Wheel With Retractable Handle
- C Disengaging Wheel
- D Articulated Transparent Screen
- E Manual Brake Lever

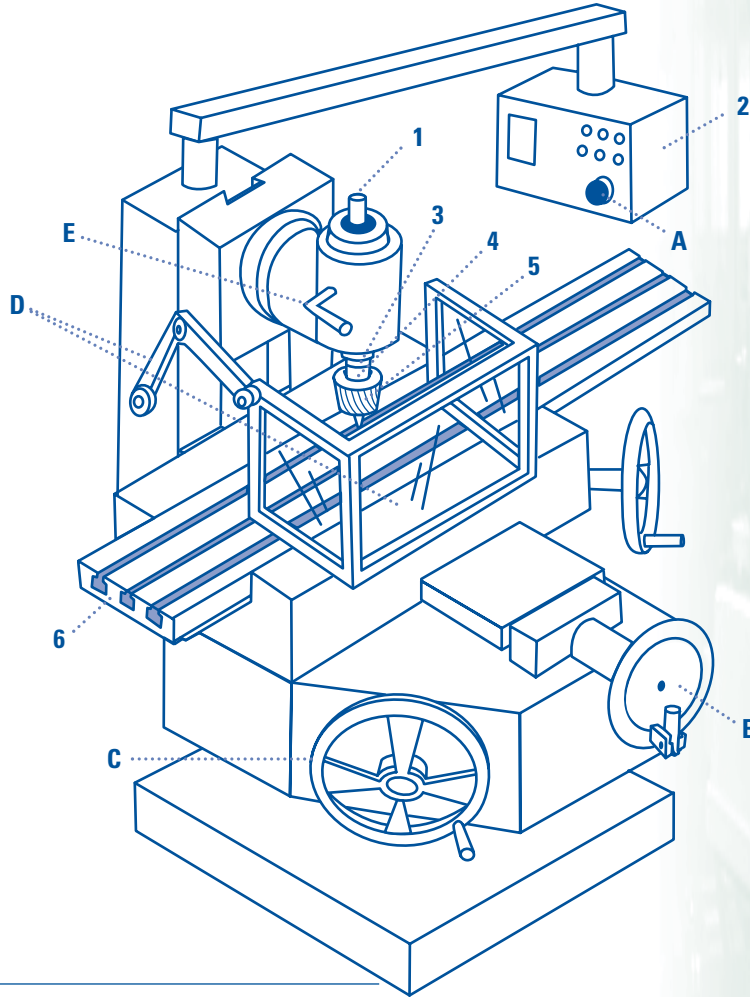

Standard Milling Machine

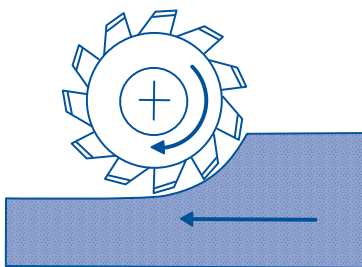

Climb milling or in-cut milling

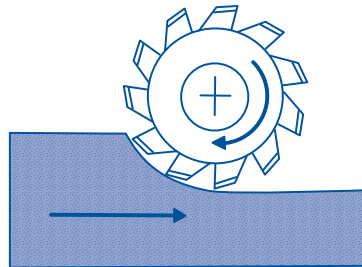

Up milling



Association paritaire pour la santé
et la sécurité du travail
Secteur fabrication de produits
en métal et de produits électriques
www.aspme.org



Institut de recherche Robert-Sauvé
en santé et en sécurité du travail
www.irsst.qc.ca



It's About Making A Difference.
Industrial Accident Prevention Association
207 Queens Quay W, Suite 550
Toronto, ON M5J 2Y3
www.iapa.ca

SELF-ASSESSMENT FORM

For Occupational Health And Safety

LEGEND

Preventative Measures

- ▶ Procedural Measures
- Orders/instructions

Priority Codes for applying risk measures:

- A. Immediate stoppage and resolution
- B. Resolution as soon as possible
- C. Resolution according to normal company procedures

The suggested preventative measures are based in part from the Workplace Health And Safety Regulations (RSST, S-2.1, r.19), from An Act Respecting Occupational Health and Safety (Québec LSST, S-2.1), as well as Milling Techniques, Module 4 — Health and Safety, edited by CEMEQ, 2000.

Mechanical Hazards

Most likely injuries: Cuts, amputations, fractures, foreign bodies, crushing, etc.

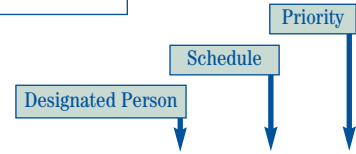

Preventative measures	Applicable <input checked="" type="checkbox"/>	Not applicable <input type="checkbox"/>	Notes	Desig.	Sched.	Prior.
Risk Factor: Contact With A Rotating Cutting Tool Or Chuck						
▶ Install a transparent safety screen (articulated, magnetic, etc.) in front of the cutting area.	<input type="checkbox"/>					
▶ Install a brake (manual, electric, etc.) to quickly stop tool rotation.	<input type="checkbox"/>					
▶ Install a nozzle to regulate the flow of cutting fluid, and place it so as to allow adjustment without having to approach the cutter or spindle.	<input type="checkbox"/>					
● Wait until the tool has come to complete stop before carrying out any work in proximity to the cutter, such as removing or adjusting a workpiece, taking measurements, removing shavings, etc.	<input type="checkbox"/>					
● To remove shavings, use a smooth, long handled brush with no rings, straps or hooks.	<input type="checkbox"/>					
● Never approach a rotating cutter while wearing gloves or holding a rag.	<input type="checkbox"/>					
● Do not wear loose-fitting clothes or any jewellery.	<input type="checkbox"/>					
● Tie up long hair and secure under a cap.	<input type="checkbox"/>					
● Register the cutter to the workpiece using an edge finder or by first applying an oil-soaked scrap of paper on the workpiece. Never register with a hand-held piece of paper.	<input type="checkbox"/>					
● Never allow the machine to run unattended.	<input type="checkbox"/>					
▶ Install an emergency stop button coupled with a brake to quickly stop tool rotation.	<input type="checkbox"/>					
Risk Factor: Accidental Start-Up Of The Milling Machine During Maintenance Or Repairs						
● Apply lockout procedures: - disconnect all sources of energy - lockout all sources of energy - verify to ensure start-up is not possible.	<input type="checkbox"/>					
Risk Factor: Access To Danger Zones Caused By A Moving Table						
● Ensure there is at least a 60cm (24in) clearance between the maximum table reach and any other obstacle.	<input type="checkbox"/>					
▶ Install an easily accessible and clearly marked emergency stop button.	<input type="checkbox"/>					
Risk Factor: Contact With a Rotating Control Wheel						
▶ Install disengaging wheels. Otherwise, install solid wheels (spoke less) that are equipped with retractable handles.	<input type="checkbox"/>					

Mechanical Hazards (continued)

Most likely injuries: Cuts, amputations, fractures, foreign bodies, crushing, etc.

Preventative measures	Applicable <input checked="" type="checkbox"/>	Not applicable <input type="checkbox"/>	Notes	Desig.	Sched.	Prior.
Risk Factor: Contact With Drive Mechanism						
▶ Install a fixed guard to limit access to moving parts: pulleys, belts, gears, etc.	<input type="checkbox"/>					
Risk Factor: Contact With Workpiece Sharp Edges, Shavings, Or Stopped Cutting Tool						
● Clamp the workpiece as far away from the cutter as possible.	<input type="checkbox"/>					
● Handle only with a rag or cut-resistant gloves.	<input type="checkbox"/>					
● Tighten clamps by pulling towards you, not away.	<input type="checkbox"/>					
● Immediately put away any unused tools.	<input type="checkbox"/>					
● Remove shavings with a brush.	<input type="checkbox"/>					
Risk Factor: Falling Material Or Milling Machine						
▶ Securely anchor the milling machine to the floor.	<input type="checkbox"/>					
● Ensure any piece overhanging the table will not fall once released from the securing clamp attachments.	<input type="checkbox"/>					
● Remove any object likely to fall from the table.	<input type="checkbox"/>					
● Use the motorized table feed or the manual controls to support heavy or bulky tools while being removed from the spindle.	<input type="checkbox"/>					
● Wear CSA-approved safety footwear with steel-capped toes.	<input type="checkbox"/>					
Risk Factor: Fall, Slipping						
▶ Install a transparent safety screen (articulated, magnetic, etc.) in front of the cutting area so as to avoid spilling shavings and fluid onto the floor	<input type="checkbox"/>					
● Reduce fluid output from nozzle to a minimum. Orient the stream of fluid so as to minimize splash.	<input type="checkbox"/>					
▶ Repair and clean floor: uneven surfaces, holes, slippery floor, presence of shavings, etc.	<input type="checkbox"/>					
▶ Supply floor mats with rising edges.	<input type="checkbox"/>					
Risk Factor: Flying Material (Keys, Screws, Cutter Fragments, Workpiece, Shavings, etc.)						
▶ Install a transparent safety screen (articulated, magnetic, etc.) in front of the cutting area.	<input type="checkbox"/>					
▶ Orient the milling machine so as to reduce the likelihood of flying material reaching adjacent workstations.	<input type="checkbox"/>					
● Check the table to ensure there are no objects that can be projected from the workstation.	<input type="checkbox"/>					
● When near a milling machine, wear CSA-approved safety glasses with lateral protection.	<input type="checkbox"/>					
● When needed, wear a CSA-approved face shield on top of safety glasses.	<input type="checkbox"/>					
● Wear long-sleeve shirts.	<input type="checkbox"/>					

Mechanical Hazards (continued)

Most likely injuries: Cuts, amputations, fractures, foreign bodies, crushing, etc.

Preventative measures	Applicable <input checked="" type="checkbox"/>	Not applicable <input type="checkbox"/> N/A	Notes	Desig.	Sched.	Prior.
Risk Factor: Flying Key or Wrench						
▶ Supply a spring-loaded chuck key.	<input type="checkbox"/>					
● Never tighten or loosen a cutter by loosening a setscrew or by turning the spindle with the motor.	<input type="checkbox"/>					
● Before starting the milling machine, make sure the key and wrench are not on the chuck or spindle.	<input type="checkbox"/>					
Risk Factor: Flying Fragments After Tool Fracture Or Flying Set Screws						
● Before commencing machining, check that the tool's cutting edges are sharp and that there are no missing or loose tips.	<input type="checkbox"/>					
● Select the shortest possible taper and cutter.	<input type="checkbox"/>					
● Properly secure the cutter to the taper.	<input type="checkbox"/>					
● Properly secure the taper to the spindle.	<input type="checkbox"/>					
● Use the shortest securing bolts possible.	<input type="checkbox"/>					
● Stop the rapid advance at a sufficient distance from the workpiece assembly.	<input type="checkbox"/>					
Risk Factor: Flying Workpiece Or Fragments From Improperly Secured Workpiece						
● Properly secure the workpiece using accepted safe work practices.	<input type="checkbox"/>					
Risk Factor: Flying Workpiece Or Fragments From Improper Cutting Parameters						
● Refer to cutter manufacturer specifications or other technical data to select a good combination of cutting parameters (feed speed, cut depth, cutting speed, lubrication) according to the material being cut, how it is going to be used and the tool that you are using.	<input type="checkbox"/>					
● In-cut mill only if the milling machine is equipped with a mechanism to take up any spindle free play.	<input type="checkbox"/>					
● Check that the cutter cuts in the same direction as the spindle.	<input type="checkbox"/>					
Risk Factor: Flying Chips And Shavings						
● Use tools with chip breakers. Alternatively, use a back-and-forth technique during machining.	<input type="checkbox"/>					
● Remove chips and curls by blowing with compressed air at a pressure less than 200 kPa (30 psi).	<input type="checkbox"/>					
● Never remove chips and curls by blowing with your mouth.	<input type="checkbox"/>					

Notes:

Ergonomic Hazards

Most likely injuries: Musculo skeletal disorders, backaches.

Preventative measures	Applicable <input checked="" type="checkbox"/>	Not applicable <input type="checkbox"/>	Notes	Desig.	Sched.	Prior.
Risk Factor: Handling Of Heavy And Bulky Workpieces						
▶ Supply mechanical handling devices (hoist, dolly with lift table, etc.) suitable to the weight and dimensions of the workpieces.	<input type="checkbox"/>					
● Ask for help from another worker when help is needed.	<input type="checkbox"/>					
Risk Factor: Straining Working Positions						
▶ Install a transparent guard, which doesn't cover the area being machined.	<input type="checkbox"/>					
▶ Install sufficient lighting to illuminate the machining area so as to eliminate the need to bend neck and back.	<input type="checkbox"/>					
Risk Factor: Static Standing Work						
▶ Supply an anti fatigue mat.	<input type="checkbox"/>					

Heat-Related Hazards

Most likely injuries: Burns.

Preventative measures	Applicable <input checked="" type="checkbox"/>	Not applicable <input type="checkbox"/>	Notes	Desig.	Sched.	Prior.
Risk Factor: Contact With Shavings, Cutting Tools And Hot Workpieces						
▶ Install a transparent safety screen (articulated, magnetic, etc.) in front of the cutting area.	<input type="checkbox"/>					
● Remove shavings with a brush.	<input type="checkbox"/>					
● Wear a long-sleeved shirt.	<input type="checkbox"/>					
● Handle hot workpieces and cutting tools with gloves or a rag.	<input type="checkbox"/>					

Physical Hazards

Most likely injury: Hearing loss

Preventative measures	Applicable <input checked="" type="checkbox"/>	Not applicable <input type="checkbox"/>	Notes	Desig.	Sched.	Prior.
Risk Factor: Noisy Workplace Environment						
▶ Install sound dampers on compressed air nozzle outlets.	<input type="checkbox"/>					
● Wear earplugs or earmuffs.	<input type="checkbox"/>					

Notes:

Chemical and Biological Hazards

Most likely injuries: Dermatitis, intoxication, infection, etc.

Preventative measures	Applicable <input checked="" type="checkbox"/>	Not applicable <input type="checkbox"/>	Notes	Desig.	Sched.	Prior.
Risk Factor: Inhalation Or Skin Contact Of Contaminants From Cutting Fluids Or The Workpiece						
● Consult the MSDS for the workpiece to determine if there are any hazardous substances (e.g., beryllium, cobalt, manganese, lead, etc.).	<input type="checkbox"/>					
▶ Dry-cut whenever possible.	<input type="checkbox"/>					
● Consult the MSDS for the cutting fluid.	<input type="checkbox"/>					
▶ Select cutting fluids that do not contain any amines-class chemical substances and that are the least harmful to your health.	<input type="checkbox"/>					
▶ Confine the machining area and install an airborne particle recovery system (dust and other airborne particles).	<input type="checkbox"/>					
● Periodically change the cutting fluid and clean all conduits to limit bacterial contamination.	<input type="checkbox"/>					
● During handling, wear gloves that are resistant to the cutting fluid used.	<input type="checkbox"/>					
● Follow the following personal hygiene precautions: - frequently wash hands and forearms with mild soap and water - promptly report, treat and cover and cuts - regularly change clothing impregnated with cutting fluid.	<input type="checkbox"/>					

Electrical Hazards

Most likely injuries: Electrocutation.

Preventative measures	Applicable <input checked="" type="checkbox"/>	Not applicable <input type="checkbox"/>	Notes	Desig.	Sched.	Prior.
Risk Factor: Contact With Parts Normally Or Accidentally Energized						
▶ Install an isolating switch with clear markings near the milling machine.	<input type="checkbox"/>					
● Apply lockout procedures during maintenance and repairs: - disconnect all sources of energy - dissipate (purge) all residual energies - lockout all sources of energy - Verify to ensure start-up is not possible and that all power has been dissipated (purged).	<input type="checkbox"/>					
● Check the power supply cables insulation and the milling machine grounding circuit.	<input type="checkbox"/>					

Completed By:

This Self-Diagnosis form was developed following a research project in workplace health and safety from IRSST, a workplace health and safety research institute named (Institut de recherche Robert-Sauvé en santé et en sécurité du travail).